

KIO-LITE-215L-WM USER MANUAL

INTOUCH

KIO-LITE-215L-WM SPECIFICATIONS

1 Touch Screen INDT215

- 21.5" active viewable area
- 10-point PCAP multi-touch
- 1920 x 1080 Native Resolution
- Built-in stereo speakers
- Compatible with Windows 7, 8 & 10

2 Media Player Intel NUC

- Intel Core i3 Processor
- Iris Plus Graphics 655
- Bluetooth* 5
- DDR4-2400 RAM
- Windows 10

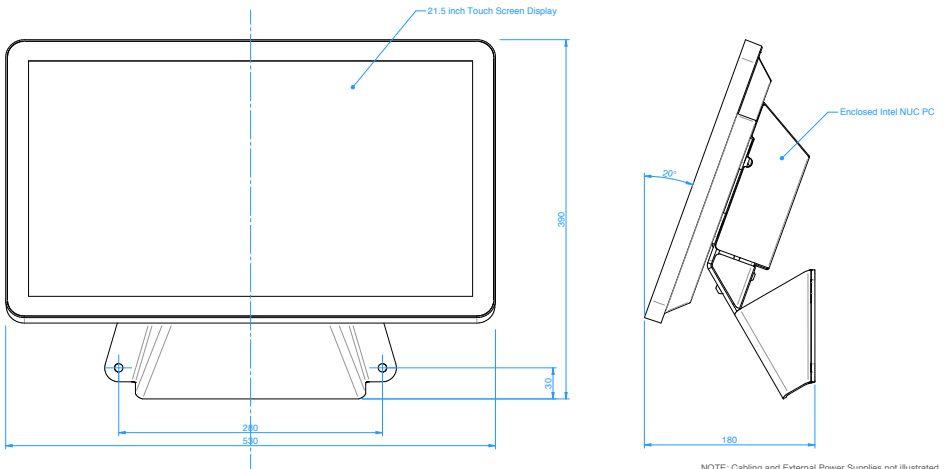

CABLING INFORMATION*

*Cabling and external power supplies not illustrated

Requirement:

You will need two power points to connect the screen and media player.

Network:

You have the option to connect the media player to your network via WiFi or Ethernet.

Setup:

Simply plug in the power cables, turn power on and you are ready to go!

KIO-LITE-215L-WM BACK VIEW*

*The default setting for the NUC is to auto start when connected to power

Intel NUC ON / OFF
button located under
the rear cover. (This
can be accessed while
the cover is in place)

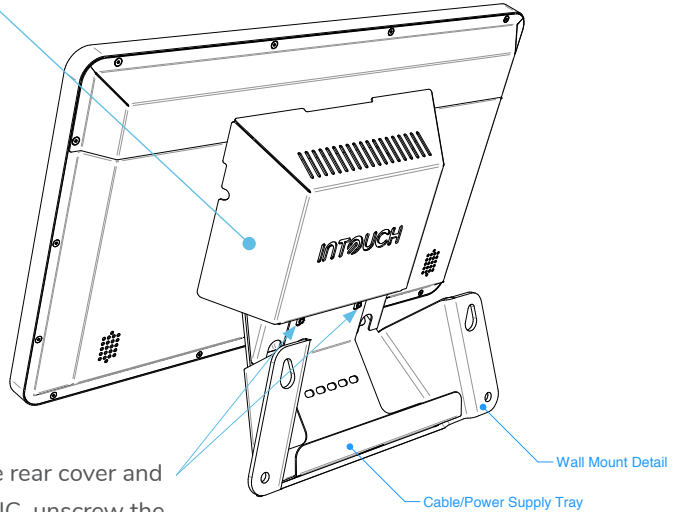

To remove the rear cover and access the NUC, unscrew the two fasteners using a 4mm allen key.

OPTIONAL ACCESORIES*

*Not shown in illustrations

- Fixed 2D Scanner
- HD Camera (Fixed or tilt-adjustable)
- EFTPOS Terminal Mounting
- RFID / Mag. Card Reader

Talk to us about your device needs! (support@intouchscreens.com.au)

SECURING YOUR KIOSK (OPTIONAL)

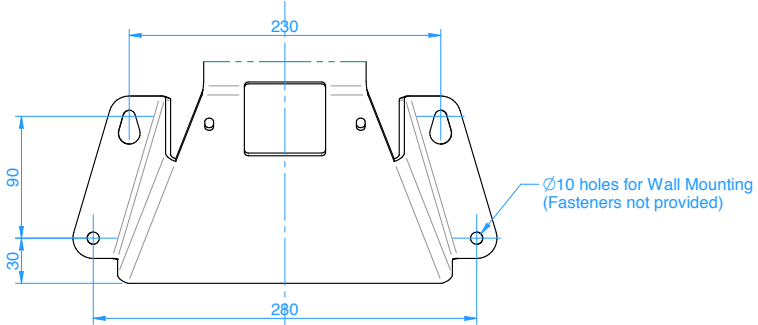

For further information on securing your kiosk, do not hesitate to contact us on support@intouchscreens.com.au

CLEANING INSTRUCTIONS

Applicable to touch screens and kiosks:

InTouch suggests using an isopropyl alcohol spray and clean microfibre cloth.

Caution: DO NOT use abrasive cleaners, solvents or cloths.

For more information please visit www.intouchscreens.com.au/cleaning

WARRANTY

For more information please visit www.intouchscreens.com.au/warranty

FOR MORE INFORMATION

Telephone 02 9939 6251

support@intouchscreens.com.au

sales@intouchscreens.com.au

www.intouchscreens.com.au

Visit our Website

