

DATA SHEET

KIO-LITE 215L-WM

WALL MOUNTED KIOSK

The InTouch KIO-LITE-215L-WM 21.5" kiosk can be neatly wall mounted. This compact kiosk has the expansion capability to add numerous peripherals such as a HD camera, mini PC, 2D barcode + QR scanner and an EFTPOS terminal.

The 21.5" industrial PCAP touch screen boasts toughened glass that can withstand high-traffic public spaces and the edge-to-edge glass allows for an easy, regular cleaning regime with isopropyl or sterilising wipes. Built to industrial standards, the robust steel constructed wall-mount is finished with a durable powder-coat finish.



The robust steel constructed stand is finished with a durable powder-coat finish and the touch screen boasts toughened glass that can withstand high-traffic public spaces and the edge-to-edge glass allows for an easy, regular cleaning regime with isopropyl or sterilising wipes.

KIOSK FEATURES

- Australian designed, manufactured and supported
- Neat cable management for a tidy presentation
- Sturdy free-standing design
- Clever modular design allows addition of multiple peripherals
- 3 Year Warranty

DISPLAY FEATURES

- 21.5" commercial-grade touch screen in landscape format
- Projected capacitive (PCAP) 10-point multi-touch
- Full HD 1920 x 1080 (16:9 aspect ratio)
- Edge-to-edge premium toughened glass for easy cleaning
- High clarity display
- Windows 10 compatible, driver free, plug-and-play
- Supports multi-touch gestures including swipe, pinch & zoom



AUSTRALIAN MADE



3-YEAR WARRANTY



10 POINT MULTI-TOUCH



EASY SET UP

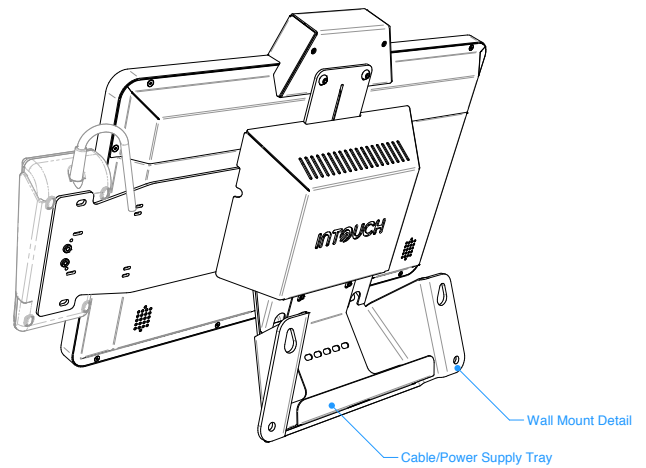
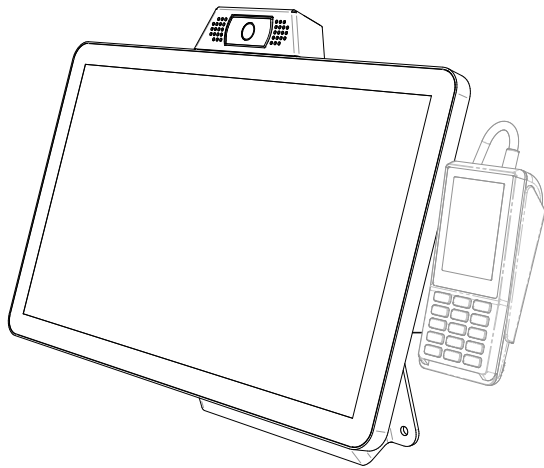
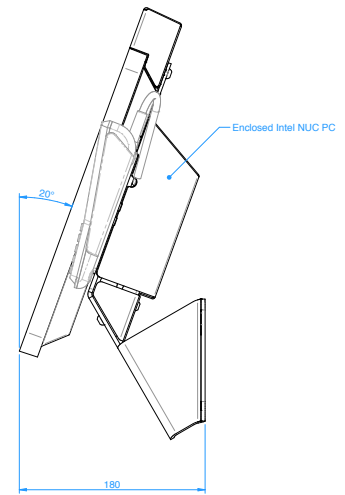
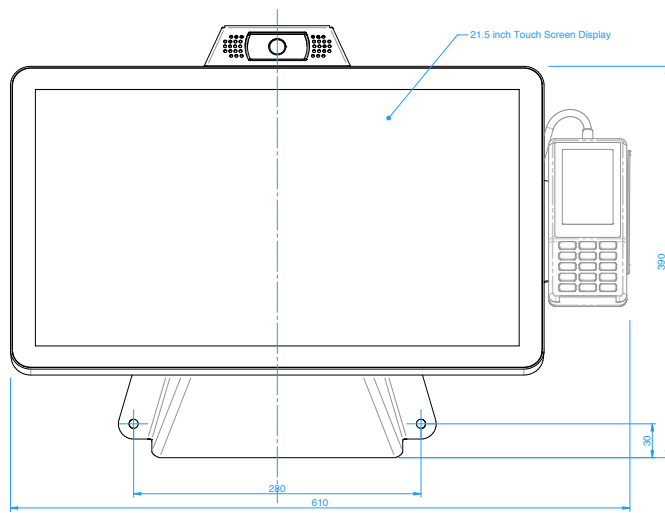

NOTE: Cabling & external power supplies not illustrated. Illustrated model includes peripheral devices.

Kiosk Options

- 2D Barcode scanner
- Kiosk PC (or BYO)
- Label printer
- Integrated camera

Technical Specifications

- 1024 x 1280 Full HD resolution
- 21.5" active viewable area
- 250cd/m2 brightness
- 1,000:1 contrast ratio
- 5ms response time
- 10-point multi-touch (PCAP)
- 50,000 MTBF Long-life Screen
- Powder-coated steel body
- Toughened glass touch surface
- Multi-touch gesture support
- Internal cable management
- Compatible with Windows 10
- PC sold separately



Our interactive KIO-LITE Kiosks are available in sizes from 19" - 22" to suit any application and available installation space.

InTouch Screens

Unit 1, 3 Green Street, Brookvale NSW 2100
1300 557 219

InTouchScreens.com.au | Sales@intouchscreens.com.au

