

KIO215VRT USER MANUAL

INTOUCH

KIO215VRT SPECIFICATIONS

1 Touch Screen INOF215

- 21.5" active viewable area
- 10-point PCAP multi-touch
- VGA & HDMI input
- 1920 x 1080 Native Resolution

2 Printer Citizen CL-S400DT (Alternate Devices Available)

- Direct thermal printing
- Industrial Auto-Cutter
- Max. print width 104mm
- Max. print length 812mm
- Two cutting modes - backfeed & cut through

3 Scanner Datalogic Gryphon GFS4400 (Alternate Devices Available)

- Reads 1D & 2D barcodes
- Wide angle field-of-view
- Reads QR Codes
- Programmable for "Always On" or "Object Sense" mode

4 Camera Logitech C922 Pro-stream Webcam

- Full HD 1080p at 30fps
- Hyperfast frame rate in HD
- Video capture capabilities
- 78° Field of view

5 Speaker Lenovo Soundbar

- USB delivered audio and power
- Dual Speaker support with 1.25+1.25 total watts of output
- Stylish and sleek design

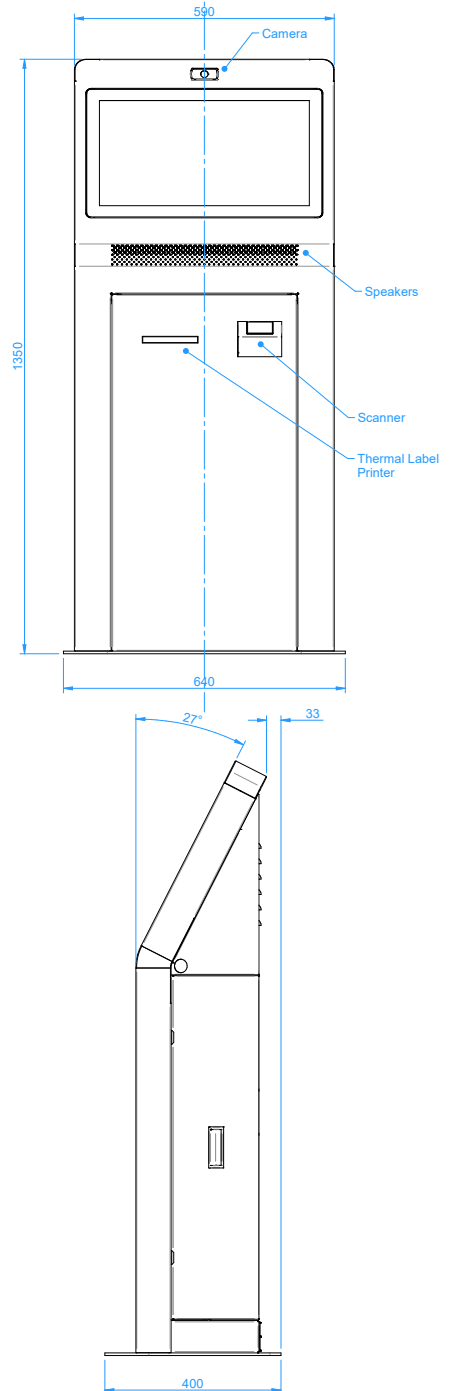

KIO215VRT INTERNAL ACCESS

Open the rear door to gain access to the printer for paper replacement.

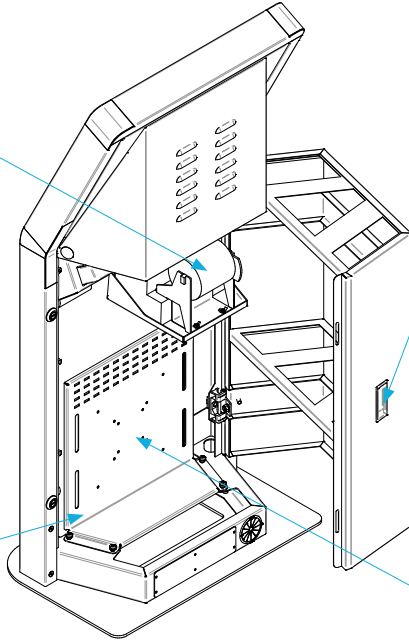

To access the inside of the kiosk. Unlock both key locks and use the handle depicted to open the door. (You may need to slightly lift the door when opening)

PC Shelf

There are multiple VESA holes to mount your PC onto the PC shelf as indicated. (It can also simply be placed on the shelf if required)

CABLING INFORMATION

Step 1. Connect your desired display cable. (HDMI Recommended)
(VGA option may not be included)



Step 2. Connect all USB devices.

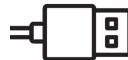

} Touch Screen
Printer
Camera
Scanner
Fan

Step 3. Connect your PC power cable into the powerboard.
(The powerboard is normally located on the PC shelf)

SECURING YOUR KIOSK TO THE FLOOR (OPTIONAL)

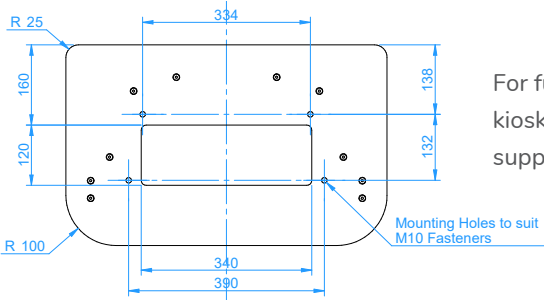

For further information on securing your kiosk, do not hesitate to contact us on support@intouchscreens.com.au

CLEANING INSTRUCTIONS

Applicable to touch screens and kiosks:

InTouch suggests using an isopropyl alcohol spray and clean microfibre cloth.

Caution: Be careful when cleaning your kiosk to avoid vinyl graphic areas so as not to damage the artwork. **DO NOT** use abrasive cleaners, solvents or cloths.

For more information please visit www.intouchscreens.com.au/cleaning

WARRANTY

For more information please visit www.intouchscreens.com.au/warranty

FOR MORE INFORMATION

Telephone 02 9939 6251
support@intouchscreens.com.au
sales@intouchscreens.com.au
www.intouchscreens.com.au

Visit our Website

